

Experimental Investigation of the Mechanical Properties of Double 'U' Notched Aluminum Alloy

Deepak Singh Bisht^{1,2}, Ravinder Singh^{1*}, P.C. Gope¹, V.K. Singh¹

¹Department of Mechanical Engineering, College of Technology, G.B. Pant University of Agriculture and Technology, Pantnagar 263145, India.

²Department of Mechanical Engineering, IFTM University, Moradabad 244102, India.

* Corresponding Author

Ravinder Singh

Email- ravinder.singh.me@gmail.com

ABSTRACT

Experimental investigation has been carried out to study the effect of notch offset distance on the fracture behaviour and load bearing capacity of aluminium alloys under three point bending loading. All the tests are conducted on 100 kN servo-hydraulic universal testing machine under displacement mode of control. The variations in mechanical properties with notch length 'a' and notch offset distance 'H' were studied on specimens under three point bending. The stiffness and ultimate load of the material is maximum for a single notched specimen and decreases as the notch offset distance was increased.

Keywords: Experimental Investigation, Aluminium alloys, Double 'U' notched, Three point bending.

1. INTRODUCTION

The strength and durability of structures may be compromised by the presence of cracks. Due to the high stress concentration in the vicinity of a crack tip it can result in the failure of the structure. The fracture mechanics theory can be used to analyze structures and machine components with cracks and to obtain an efficient design. The fracture mechanics has obtained a desirable want in studying the nature of the crack growth under the influence of static and dynamic loads. Several types of failures have resulted due to the effect of the cracks and stress raiser in the manufactured parts on their failure strength. Reason for the fracture of the stressed component containing cracks has been an interesting and challenging analysis for the designers in the field of fracture mechanics. Multiple cracking is one of the most common problems in ageing aircraft, pressure vessel and piping components. Such cracking often occurs in localized patches or colonies owing to various types of material failure, such as in stress corrosion cracking (Leis, 1997), fatigue (Soboyejo, 1990) and corrosion fatigue (Wang, 1996). U or V-shaped notches are extensively used in the design of engineering components. Gears, screws, bolts and nuts are some of the well-known machine elements that contain sharp or rounded-tip V-notches. Since V-notches decrease dramatically the load bearing capacity of components due to the concentration of stress at the vicinity of their tips, sudden fracture is one of the major failure modes in V-notched brittle materials (Ayatollahi, 2010).

Several investigators have studied the problem of interaction of multiple cracks using the numerical techniques like the finite element method, boundary element method, integral transform approach, etc. The studies conducted on the interaction of multiple cracks using the numerical techniques have found that the interaction of the cracks depend upon the geometric parameters like the crack tip distance, crack offset distance, angle of inclination, crack length etc. In the present scenario, the effect of the notch on the specimen is the main area of concern for predicting the life of the component. Because of the factor that as the cracks or notches are generated in the metal, it decreases its strength. The effect of the multiple

notches, notch length and notch offset distance are the main variants to predict the overall strength of the material. For that, the experiment was performed on different notch length and notch offset distance in aluminum alloy under three point bending. Aluminum is taken as a material of the specimen due to its high ductility, high strength weight ratio and good machinability.

There are mainly two major areas used in the present investigation i.e. material testing, fracture mechanics and result evaluation. Testing is used to determine the mechanical properties such as ultimate load, yield load, flexural stress, flexural strain, flexural modulus and fracture toughness under three point bent test and tensile test. Evaluation is used to determine the error factor between the predicted and the actual values of different parameters as described above. It is also used to see effect of the notch length and notch offset distance from the notch at the centre of the specimen on the ultimate load, yield load, flexural stress, flexural strain, flexural modulus and fracture toughness of the specimen.

2. EXPERIMENTAL ANALYSIS

2.1. Method of Specimen Preparation

The mechanical properties (shown Table 2) have been determined by tensile tests on 100 kN servo hydraulic control Universal Testing Machine (100 kN ADMET, USA make) under displacement control mode as shown in the Fig. 1. All specimens (shown Fig 2. And Table 3)is prepared according to the ASTM-E8 standard. The specimens are prepared for tensile and three point bending test of thickness of 7 mm and 10 mm from the aluminum alloy plate. The dimensions of the specimen are 150x30 x 10 and 150 x 30 x 7. The gauge length for this case is kept 150 mm and the span length is 120mm (between the roller supports). All tests are conducted in accordance with ASTM-E8 standard at cross head speed 1 mm/min.

2.2.COMPOSITION OF ALUMINUM ALLOY

Aluminum alloyis used to conduct the experiments for present investigation. Aluminum alloy used has a composition shown below in Table 1.As determined on the basis of energy dispersive spectrometry with equipment JSM-6610IV.



Fig 1. Specimen loaded on Universal Testing Machine

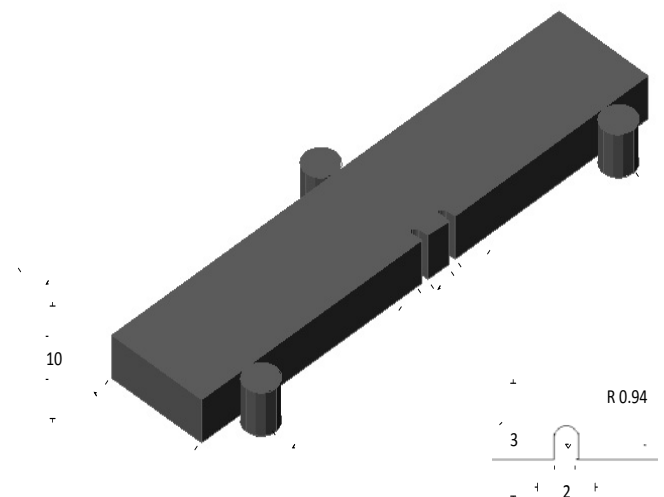

Fig 2. Specimen geometry in mixed mode loading under three point bending (All dimensions are in mm)

Table 1. Chemical composition of Aluminum alloys (wt %)

Material	Width (mm)	Al	Ag	Mg	Fe	Zn	Si	Cu	Ti	Mn	Cr	Other Elements
Al alloy	7	82.5	1.76	0.97	0.44	0.27	0.5	0.22	0.1	0.06	0.04	13.1
Al alloy	10	74.2	1.63	0.81	0.54	0.29	0.5	0.25	0.15	0.13	0.05	21.4

Table 2. Mechanical properties of Aluminum alloy

Sl. No.	Depth (mm)	Yield Strength (MPa)	Ultimate strength (MPa)	Modulus of Elasticity (MPa)	% Elongation
1	7	98.99	105.49	13526.60	4.49
2	10	75.05	95.07	5520.33	13.97

Table 3. Specimen Geometry and there Relative Positions for B= 10 mm and B= 7mm

Sl. No.	Notch size (mm)		Span length L(mm)	Width W(mm)	Relative Position H(mm)
	a ₁	a ₂			
1	3	0	120	30	0
2	3	3	120	30	3
3	3	3	120	30	4
4	3	3	120	30	5
5	3	3	120	30	6
6	3	3	120	30	10

Mechanical U-notches were made at the center of the plate at different notch offset distances. The actual notch radius is measured by help of Auto CAD software. The measured values of Notch radius (R) = 0.654 and Angle (θ) = 14 degree

3. RESULT AND DISCUSSION

The uniaxial stress-strain behavior of the specimen has been studied on servo-controlled computerized universal testing machine under displacement control mode. The variation of the load-deformation for different configuration with notches at constant notch depth ratio and different notch offset distances at constant crosshead speed of 1 mm/min for 7 mm and 10 mm thick specimens have been shown in the Fig 5-6. We see that the notch offset distances (H=4, 5, 6) give variation.

3.1. Load-Deformation Behaviour For Different Notch Offset Distance (H)

Figure 5. Shows the effect of notch offset distance on the load-deformation behaviour for aluminium alloys of plate thickness B= 7 mm. The modulus of elasticity, ultimate load and area under the load-deformation curve are found 3735.3 MPa, 5800.3 N and 8.774 N-mm respectively for notch length a₁= 3 mm and H= 0. At H= 3 mm, the modulus of elasticity, ultimate load and area under the load deformation are found as 3212.4 MPa, 5259.5 N and 10.34 N-mm respectively. From these results it can be seen that the modulus of elasticity and ultimate load are decreased by 14% and 9% respectively for H= 3 mm as compared to H= 0. while area covered under the load-deformation curve is increased by 18%. On further increase of offset distance to 4 mm, 5 mm, 6 mm and 10 mm, the modulus of elasticity are found as

3504.9 MPa, 3635.6 MPa, 3677.7 MPa and 4147.4 MPa. These results overall shows that there is an decrease and increase of modulus of elasticity at H= 4 mm, H= 5 mm, H= 6 mm and H= 10 mm respectively as compared to single notched three point bend specimen by 6.16%, 2.66%, 11.03 % and 1.54% respectively. Similarly, at notch offset distance of 4 mm, 5 mm, 6 mm and 10 mm, the ultimate load is found as 4266.3 N, 5566.6 N, 2771 N and 4942.8 N respectively. This shows that the ultimate load decreases as compared to single notched three point bend specimen by 26.44%, 4.02%, 52.22% and 14.78%.The area under the load deformation curve at notch offset distance of 4 mm, 5 mm, 6 mm and 10 mm are observed as 9.27 N-mm, 12.85 N-mm, 5.15 N-mm and 8.33 N-mm. It is seen that the area under the curve increases s compared to single notched three point bend specimen by 5.74%, 46.45%, 41.23% and 5.03% respectively.

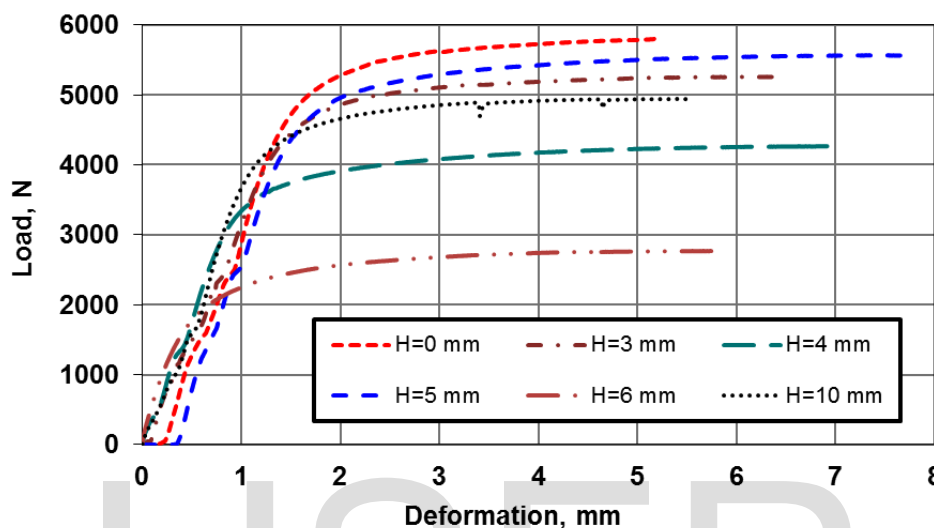

Fig 5. Load-deformation behaviour for different notch offset distance (H) at U-notch depth ratio (a_2/a_1) of 1 and B= 7 mm

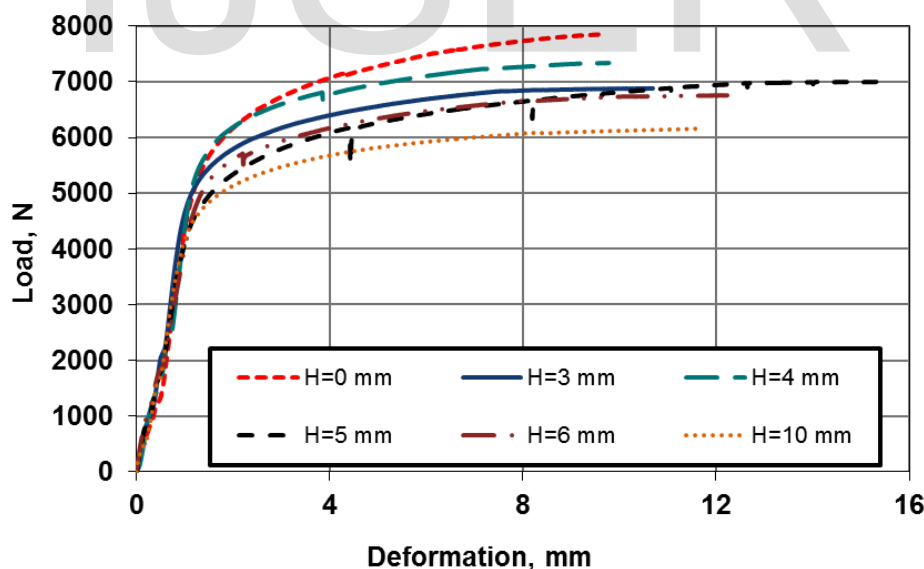

Fig 6. Load-deformation behaviour for different notch offset distance (H) at U-notch depth ratio (a_2/a_1) of 1 and B= 10 mm

Figure 6. Shows the influence of notch offset distance on the load-deformation behaviour for aluminium alloys of plate thickness B= 10 mm. The modulus of elasticity, ultimate load and area under the load-deformation curve are found 4535.2 MPa, 7853.4 N and 15.68 N-mm respectively for notch length $a_1= 3$ mm and H= 0. At H= 3 mm, the modulus of elasticity, ultimate load and area under the load deformation are found as 3884.9 MPa, 7611.5 N and 21.72 N-mm respectively. By

this, it can be observed that the modulus of elasticity, ultimate load and area covered under the load-deformation curve are decreased by 14.33% and 3.08% and 38.52% respectively for H= 3 mm as compared to H= 0. On further increase of offset distance to 4 mm, 5 mm, 6 mm and 10 mm, the modulus of elasticity are found as 4441.3 MPa, 4747.7 MPa, 3916.7 MPa and 4424.2 MPa. These results overall conclude that there is an decrease of modulus of elasticity at H= 4 mm, H= 6 mm and H= 10 mm as compared to single notched three point bend specimen by 2.07%, 13.63% and 2.44%. At H= 5 mm modulus of elasticity is increased by 4.68%. Similarly, at notch offset distance of 4 mm, 5 mm, 6 mm and 10 mm, the ultimate load is found as 7341.8, 7407.2 N, 6762.5 N and 6158.9 N respectively. This found that the ultimate load decreases as compared to single notched three point bend specimen by 6.51%, 5.68%, 13.89%, and 21.57%. The area under the load deformation curve at notch offset distance of 4 mm, 5 m and, 6 mm are observed as 19.9 N-mm, 23.6 N-mm and 26.1N-mm. It is observed that the area under the curve increases as compared to single notched three point bend specimen by 27.52%, 51.28% and 67.3%.

3.2. Effect Of Notch Offset Distance (H) On Energy Storing Capacity

Figure 7. Shows the effect of notch offset on the energy storing capacity for aluminium alloys of plate thickness B= 7 mm and B= 10 mm at notch depth ratio of 1. The strain energy stored are found 8.774 N-mm and 11.583 N-mm for B= 7 mm and B= 10 mm respectively for notch length $a_1= 3$ mm and H= 0. At $a_2/a_1= 1$, B= 7 mm and notch offset distance of 3 mm, 4 mm, 5 mm and 6 mm and 10 mm, the energy stored are found as 8.333 N-mm, 9.275 N-mm, 12.853 N-mm, 10.341 N-mm and 15.239 N-mm respectively. By this, it can be found that at H= 3 mm, a decrease of 50.62% and at notch offset distance of 4 mm, 5 mm and 6 mm and 10 mm, an increase of 5.7%, 46.52%, 17.9% and 73.66% of energy stored as compared to single notch three point bend specimen respectively. Similarly, B= 10 mm and notch offset distance of 3 mm, 4 mm, 5 mm and 6 mm and 10 mm, the energy stored are found as 18.99 N-mm, 17.705 N-mm, 20.524 N-mm, 22.485 N-mm and 18.48 N-mm respectively. This result indicates that there is an increase of 63.21%, 52.84%, 94.12%, 40.15% and 59.58% of energy stored as compared to single notched three point bend specimen respectively.

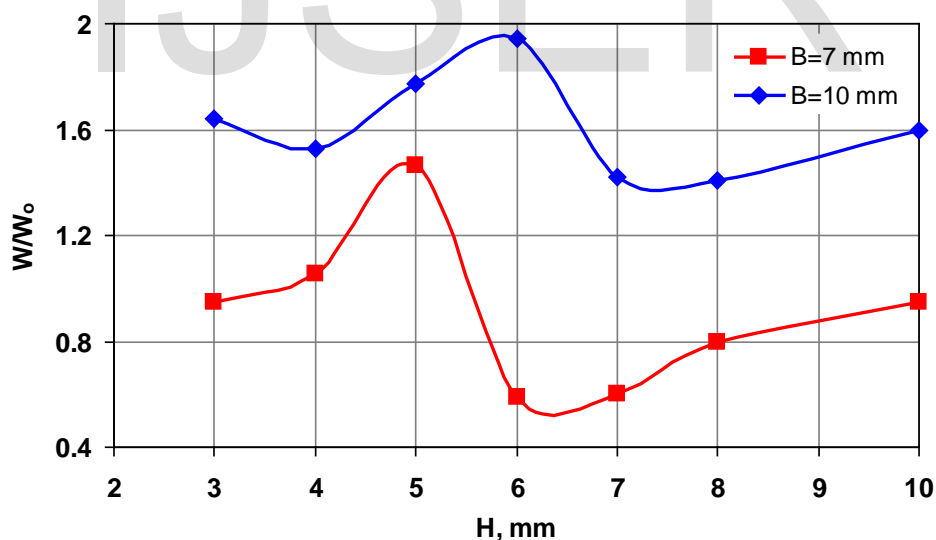

Fig 7. Energy ratio- Notch offset distance (H) behavior at notch depth ratio (a_2/a_1) of 1 for different thickness of the specimen

4. CONCLUSION

4.1. Effect Of Notch Offset Distance On The Mechanical Properties

At B= 7 mm, the notch offset distance increases H= 0 to H= 3 that the modulus of elasticity and ultimate load are decreased by 14% and 9% respectively. While area covered under the load-deformation curve is increased by 18%. On further increase of offset distance to 4 mm, 5 mm, 6 mm and 10 mm, the modulus of elasticity start decreasing on further increase notch offset distance 6.16%, 2.66%, 11.03 %

and 1.54% respectively. The ultimate load decreases on increasing the offset distance by 26.44%, 4.02%, 52.22% and 14.78%. The area under the load deformation curve on increasing the notch offset distance increases 5.74%, 46.45%, 41.23% and 5.03% respectively. At $B=10$ mm, the modulus of elasticity, ultimate load and area covered under the load-deformation curve are decreased by 14.33% and 3.08% and 38.52% respectively for $H=3$ mm as compared to $H=0$. On further increase of offset distance the modulus of elasticity is decreased further increases at $H=5$ mm after that decreases again. The ultimate load decreases on increasing the notch offset distance by 6.51%, 5.68%, 13.89%, and 21.57%. The area under the load deformation curve increases on increasing the notch offset distance by 27.52%, 51.28% and 67.3%.

4.2. Effect Notch Offset Distance On The Energy Storing Capacity

The variation of the energy stored at constant notch depth ratio (a_2/a_1) of 1 for 7 mm and 10 mm thickness specimen shows that firstly the energy storing capacity increases with increase in the value of H till $H < 5$ mm. On further increase in the value of H , the energy storing capacity of the material decreases for $B=7$ mm. It can be found that at notch offset distance $H=3$ mm, a decrease of 50.62% and notch offset distance of 4 mm, 5 mm and 6 mm and 10 mm, an increment of 5.7%, 46.52%, 17.9% and 73.66% respectively. At $B=10$ mm, notch offset distance of 3 mm, 4 mm, 5 mm and 6 mm and 10 mm result indicates that there is an increase of 63.21%, 52.84%, 94.12%, 40.15% and 59.58% of energy stored as compared to single notched three point bend specimen respectively.

REFERENCES

- [1] Ayatollahi, M.R. and Torabi, A.R. 2010. Brittle fracture in rounded V-shaped notches. *Mater Des.* 31(1): 60–7.
- [2] Erdogan, F., Sih, C.G. 1963. On the crack extension in plates under plane loading and transverse shear. *J Basic Eng.* 85: 528–34
- [3] Griffith, A.A. 1921. A phenomenon of rupture and flow in solids. *Phil. Trans. Royal Soc.* 221: 163–98.
- [4] Inglis, C.E. 1913. Stress in plate due to the presence of crack and sharp corners. *Trans. Int. Nov.* 60: 219–30.
- [5] Leis, B.N. and Mohan, R. 1997. Coalescence conditions for stress-corrosion cracking. *Proceedings of the Seventh ISOPE.* 4: 607–13.
- [6] Lam, K.Y. and Phua, S.P. 1990. Multiple crack interaction and its effects. *Eng. Fract. Mech.* 40(3): 585–92.
- [7] Qing, H. and Yang, W. 2006. Characterization of strongly interacting multiple cracks in an infinite plate. *Theor. Appl. Fract. Mech.* 46: 209–16.
- [8] Soboyejo, W.O. and Knott, J.F. 1990. Fatigue crack propagation of coplanar semi elliptical cracks in pure bending. *Eng. Fracture Mech.* 37: 323–40.
- [9] Wang, Y.Z., Atkinson, J.D., Akid, R. and Parkins, R.N. 1996. Crack interaction, coalescence and mixed mode fracture mechanics. *Fatigue Fracture Eng. Mater. Struct.* 19: 427–39.
- [10] Wang, X.F., Hasebe, S. 2000. Bending of a thin plate containing a rigid inclusion and a crack. *Engineering Analysis with Boundary Elements.* 24: 145–53.
- [11] Xiangqiao, Y. and Chang, M. 2012. Interaction of Multiple Cracks in a Rectangular Plate. *Appl. Math. Modelling. Int. J. Fract.* 30: 13–20
- [12] Yan, X. 2005. An effective boundary element method for analysis of crack problems in a plane elastic plate. *Appl. Math Mech.* 26(6): 814–22.